

The Mercedes-Benz S-Class. Lead the World.



Mercedes-Benz



Attracts so much attention. Now even more attentive in return.

What can we give someone who's already been everywhere? What surprises are left, when every upcoming situation is foreseen in advance? How do you persuade people who are themselves already experts in persuasion? By showing attention. By showing respect. By showing appreciation. In each case to a hitherto unknown level. Enjoy the new S-Class. **Feel Intelligent Drive.**



No need to prove anything to anyone. Except to itself.

For example, that you cannot be too careful in the way you manage resources. That the ultimate in refinement is still some way off. That economy and opulence are not mutually exclusive concepts, but ones that complement each other perfectly. As a case in point, the new S-Class makes its debut with a completely redesigned generation of engines. With the most intelligent assistance systems in its class. With sensory stimuli that captivate both body and soul.





 Mercedes-Benz

Always quick to slows things down.

There are so many technologies that make our life faster. In the new S-Class one piece of equipment is premiering that can stop your world for a moment: ambient lighting in 64 colors provides an activation of colours in addition to sounds, lights, scents and even seat massages. Subtle vitalising or relaxing effects help to keep the driver fit and composed behind the wheel.

*Please read the disclaimer.



Show who you are. Not what you have.

Character and prestige are literally written all over the face of the new S-Class. The optional MULTIBEAM LED headlamps make a particularly striking impression. A total of 84 LEDs turn illuminating the road into a fine art. An exclusive light design lends the S-Class a distinct appearance in the dark, too.

*Please read the disclaimer.



How are you?

An important question, as your well-being is a key safety factor. That's why the new S-Class actively attends to its passengers' physical and mental well-being. Since 1972, every S-Class has stood for outstanding comfort, but today we are talking about an entirely new quality.

*Please read the disclaimer.

Mercedes-Benz Intelligent Drive – pointing the way to accident-free and autonomous driving.

Mercedes-Benz is the first automotive manufacturer worldwide to have developed an integral safety concept, with the aim of safe driving, responding in an appropriate manner to hazards, avoiding accidents and mitigating the consequences of accidents. For the occupants of a Mercedes and for all other road users, too.

Mercedes-Benz Intelligent Drive forms part of this integral safety concept. It makes your Mercedes one of the most intelligent automobiles in the world – an “intelligent partner”. The Mercedes-Benz Intelligent Drive assistance systems are able to recognise hazards, provide timely warnings and even intervene autonomously when necessary – by performing braking manoeuvres, for example. In this way, accidents can be prevented or the severity of accidents can be significantly reduced. In order to protect passengers as necessary in case of dangers.

Mercedes-Benz S-Class first time offers a Driving Assistance Package in India. The key functions of this package include partially automated driving on highways. The Driving Assistance package also lends support when some other vehicle is in the blind spot of your car, for example during overtaking. This relieves the driver’s workload, as in normal driving they no longer need to brake or accelerate. The driver also receives substantial support with steering – even in bends.

Never before have safety, comfort and measures to reduce the strain on the driver been combined so effectively. This intelligent and pioneering interplay of sensors and safety and assistance systems represents a milestone on the road to autonomous and accident-free driving. And a fascinating new experience into the bargain.

Disclaimer: Please note that the assistance systems referred to are only aids. They are not a substitute for the driver’s awareness of the surroundings. The driver bears responsibility throughout the entire journey and must intervene when necessary.

*Please read the disclaimer.



Engines.

S 350 d (OM656)

The most powerful diesel engine in the history of Mercedes-Benz bundles together state-of-the-art technology components. As a result, the engine sets standards in terms of agility and consumption. More than an additional bonus: the six-cylinder in-line engine boasts an unsurpassed level of refinement.

Key features:

- Variable valve lift (CAMTRONIC) on the exhaust side – makes emission control even more efficient and means the engine is an environmental diesel
- NANOSLIDE® together with cylinder barrels as used by Mercedes-Benz in Formula 1 – ideal lubrication, reduced friction and very high wear resistance thanks to extremely hard cylinder contact faces with minuscule pores for oil absorption
- Ideal combination with high-tech steel pistons – these reduce friction as steel expands less compared with aluminium when subjected to heat, and pistons and cylinder walls can be adjusted even more perfectly
- 2-stage turbochargers (connected in series, the small turbocharger features variable turbine geometry) – for impressively sporty acceleration
- Water-cooled turbocharger housing in combination with air/water charge air cooler – for better performance and even more agile response
- Common rail direct injection with piezo injectors and unparalleled high injection pressure of up to 2500 bar – this atomises the fuel even more finely and reduces soot formation among other things, while also benefiting engine warm-up and noise levels
- Crankcase (engine block) and cylinder head made of aluminium reduce engine weight and thus the weight on the front axle

Environmental features:

All technologies for emissions control are implemented directly on the engine, not further away as is usually the case. As a result they do not need to be specifically heated up: fewer emissions and lower consumption, in particular in the case of cold starts and in the low load range. 3rd-generation NOx aftertreatment: the AdBlue® solution evaporates in a highly efficient manner along the shortest possible route in the exhaust gas flow Multiway exhaust gas recirculation: even more exhaust gases are recycled during the combustion process.



*Please read the disclaimer.

Engines.

Petrol Engine

Refinement, driving pleasure and responsibility – embodied by the petrol engine with 270 kW (367 hp). Thanks to twin turbocharging and intercooling, the S 450 has huge reserves of power. The engine may give off its typical, unmistakably sonorous and cultivated sound, but fuel consumption stays unusually low.

Note: Not conducive for driving in waterlogged roads with still water depth more than 25 cm.

Key features:

- Crankcase and cylinder head of aluminium, incorporating zirconium alloys to dissipate the heat more efficiently for maximum engine output and stability even at the limits
- Petrol particulate filter reduces minute soot particles and significantly undercuts even the most stringent limits (only part of the exhaust aftertreatment in the underfloor area)
- Exhaust aftertreatment directly on the engine for a more powerful and faster response and less dependence on ambient temperatures or driving style
- Plastic engine mounts reduce vibration
- Impressive start-off with absolutely no turbo lag
- Variably adjustable intake and exhaust valves filled with sodium – optimally designed for the peak temperatures of the high-performance engine and also very light
- This bridges the time delay before the large turbocharger goes into powerful action, three times for two seconds or once for 15 seconds per minute
- This dethrottles the exhaust system and the engine responds more directly to the accelerator
- Sophisticated acoustic cladding for quieter operation
- An electric auxiliary compressor supplies even more charge pressure and therefore additional torque from just above idle speed

- Twin-scroll turbocharger with air/water charge-air cooling and two-flow exhaust routing – the ducts, each from two cylinders, are separate and come together only just before the turbine.
- Highly efficient direct injection system with demand-controlled multiple injection and multi-spark ignition for optimal mixture formation
- Cylinder barrels lined in NANOSLIDE® technology (iron/carbon) – ideal piston lubrication with reduced friction and wear thanks to extremely hard surfaces with minute pores for oil retention.

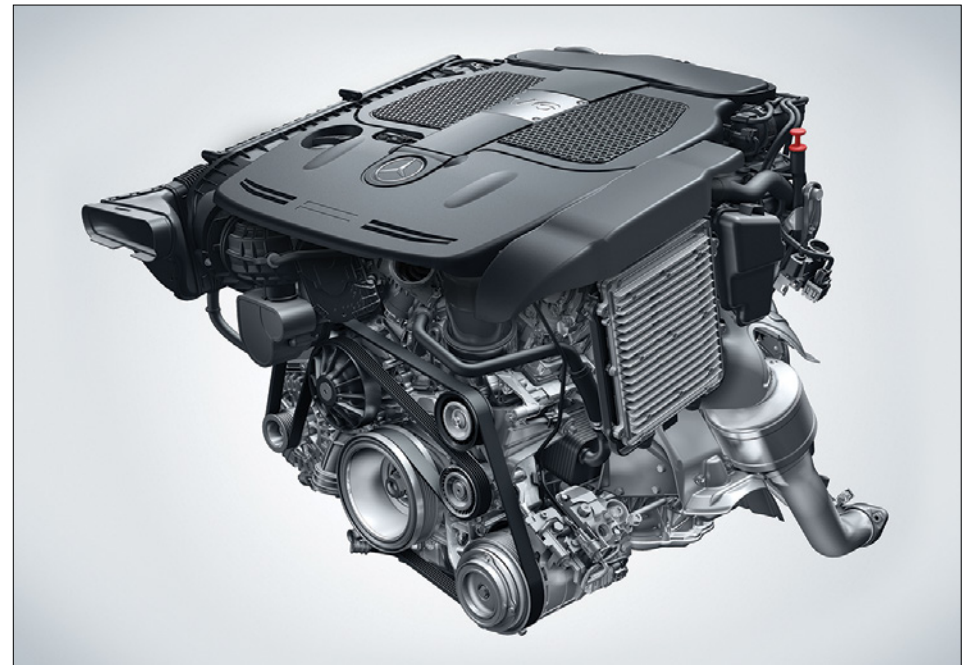

*Please read the disclaimer.

Using innovation to counteract lateral forces.

AIRMATIC: Working in combination with a stepless damping control system, this air suspension system ensures superlative road roar and tyre vibration characteristics and driving dynamics. The damping is adjusted on each wheel to the actual driving situation and can be set to be comfortable or sporty, as desired. Thanks to the pneumatic all-round self-levelling suspension, the vehicle maintains a constant level irrespective of the payload. To increase ground clearance on poor surfaces or ramps, the suspension can be raised by

up to 30 mm at the touch of a button when the engine is running – both when stationary and on the move. From a speed of 100 km/h the suspension level is automatically lowered by 20 mm in “Sport” mode. In “Comfort” mode the suspension level is initially lowered by 10 mm from a speed of 120 km/h, and by another 10 mm from 160 km/h. The lowering action reduces aerodynamic drag and therefore fuel consumption, while improving handling stability thanks to a lower centre of gravity.

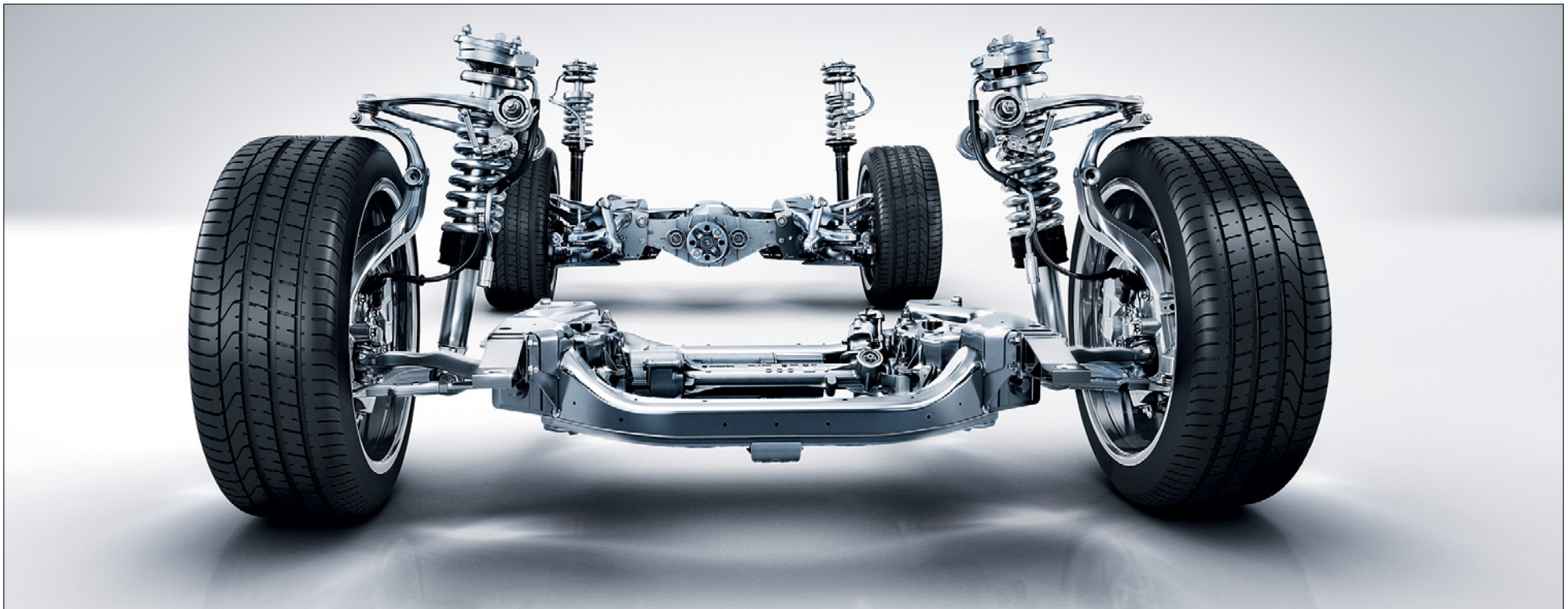

Safety and Assistance systems.

Driving Assistance package - more stress relief, more safety, more protection

Assisted driving on highways, assisted situation-dependent braking in critical situations when needed, and active assistance during evasive manoeuvres – these are just some of the functions of the Driving Assistance package. The aim: more comfort and less stress by relieving the driver's workload, thereby improving safety for all road users.

Active Distance Assist DISTRONIC and Active Steering Assist – providing support with driving, reducing stress

The Active Distance Assist DISTRONIC is able to support the driver with controlling the distance to the vehicle in front, up to a speed of 210 km/h. The desired speed can be set between 20 km/h and 210 km/h. At low speeds, the system can also react to stationary vehicles. If the vehicle is braked to a complete stop at the end of stop-and-go traffic by the Active Distance Assist DISTRONIC, it can move off again up to 30 s later without the driver having to intervene.

Active Blind Spot Assist

Active Blind Spot Assist can warn the driver of vehicles in the blind spot during a lane change and can help to avoid a collision.

Active Braking Assist – warning, situation-dependent braking assistance and autonomous braking

If an accident risk is detected, the system can warn the driver, assist with emergency braking and, in an emergency, apply the brakes automatically. It can detect slower-moving, stopping and stationary vehicles as well as, vehicles at the end of a tailback and pedestrians in the danger zone with the aid of radar sensors and the stereo camera. If danger is detected, the system gives the driver a visual and audible warning. If the driver reacts and brakes, it can boost the braking effect as the situation demands if required, right up to full brake application. If the driver fails to respond, Active Braking Assist is able to brake the vehicle in accordance with the situation. Up to a speed of approx. 130 km/h it can at least mitigate the severity of the accident – all within the respective system limits.

Tyre pressure monitoring system

The system monitors the tyre pressure for you and provides you with a warning in the event of a drop in pressure. This way you can react more quickly to these hazardous situations. Too low a tyre pressure can also result in longer stopping distances. When the control systems notifies you, you should top up the air quickly. Correct tyre pressure additionally increases mileage.

Active Steering Assist

Active Steering Assist provides additional steering torque to help the driver keep the vehicle in the centre of its lane on straight stretches of road or slight bends. This assistance system bases its actions on the road markings on both sides at speeds up to 210 km/h. If the markings are missing or unclear, as well as at speeds up to 130 km/h, the system also uses vehicles travelling in front for orientation. If Active Steering Assist is active, a green steering-wheel symbol is displayed in the instrument cluster.

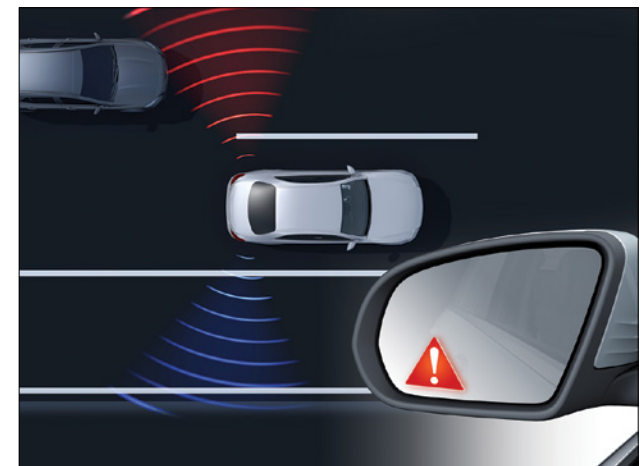

*Please read the disclaimer.

Safety and Assistance systems.

Adaptive Highbeam Assist Plus

Drive with permanent main beam. This virtually turns night into day and relieves the strain on you in your driving duties. See very far, don't dazzle – the Adaptive Highbeam Assist Plus works according to this motto. The intelligent system spares oncoming traffic or vehicles in front with highly precise LEDs: you do not have to keep on changing over to low-beam headlamps.

360° camera

The 360° camera combines the image from 4 different near-range cameras: in the radiator grille, in the exterior mirror housings and at the rear. The media display then shows you your vehicle with all 4 vehicle sides including the surroundings. For the best possible visibility when parking and manoeuvring, you can select different views: a bird's-eye view with detailed view or full image view towards the front or rear. The media display provides a maximum of 2 views. As standard, on the left you can see the "Top View" – a bird's-eye view of the vehicle and its surroundings – and also a detailed view on the right. These switch automatically, for example when you change between forward and reverse gear.

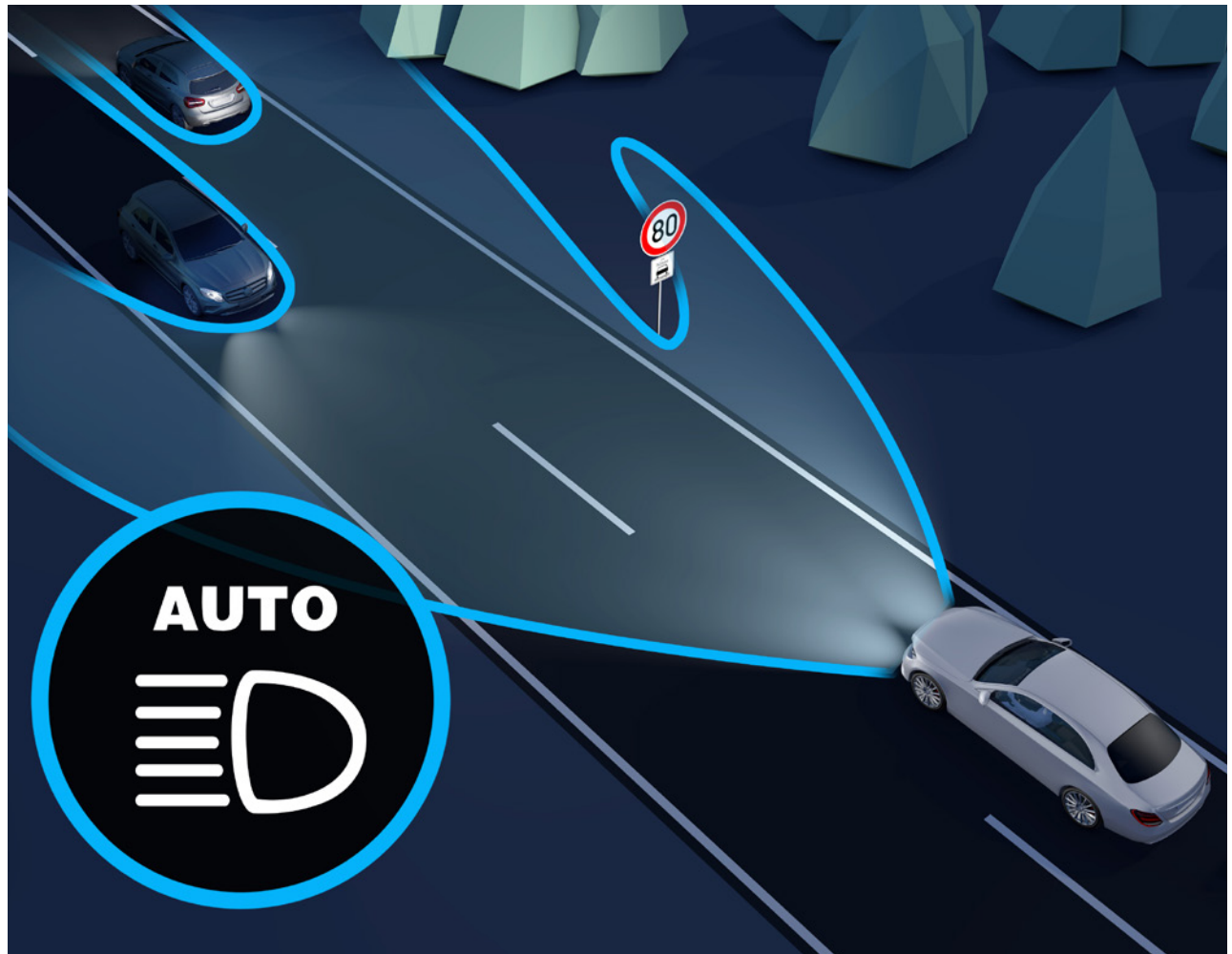

Only an S-Class looks this far ahead.

MULTIBEAM LED enables extremely fast and precise adjustment of the headlamps to the given traffic situation. The light can always be switched on precisely where it is required via 84 individually controllable LEDs. A total of four control units calculate the ideal light pattern 100 times per second using information from a camera behind the windscreen.

If no other road user is detected, the road is straight and the vehicle speed is over 40 km/h, the additional ULTRA RANGE Highbeam goes on automatically. The maximum legally permitted light intensity is produced, which means that the brightness of the main beam falls short of the reference value of one lux only at a distance of more than 650 metres. When the system detects motorway conditions, an optimised high beam pattern is selected accordingly. Motorway high beam reduces the risk of dazzling oncoming trucks and focuses the driver's attention on their own lane. In combination with COMAND Online, the cornering light with roundabout function already activates the cornering light function prior to entering a roundabout.

More than a nice gesture: When locking and unlocking the vehicle, the locator lighting greets and takes its leave of the driver with an exceptional light display featuring changing colours. The LED tail lights with crystal look are also integrated in the Coming Home function.



The rear end design boldly demonstrates the power and dynamism that the new S-Class embodies. New crystal-look rear lamps have the appearance of jewels, while three horizontally running fibre optic elements serve as a defining design feature. So-called multi-level functionality for the brake light additionally optimises driving safety for road users following the vehicle as well.

The rear lamps show a characteristic design by day and night. The advantages of their LED technology include better visibility, a considerably longer operating life and lower power consumption than conventional bulbs. The light intensity of the turn signal indicators and brake lights varies according to the prevailing light conditions and the vehicle's speed.

MORE LIGHT, BETTER VISIBILITY

The standard-specification **LED High Performance headlamps** provide for enhanced safety at night and a distinctive, striking look. LED technology illuminates the road ahead better than conventional headlamps – and it consumes less energy.



Exteriors.

Surround lighting with projection of brand logo (Available with S 450 Maestro Edition)

Surround projection of brand logo showcases an attractive eye-catching feature in dark surroundings and additional light also makes it more convenient for you when getting in and out. This comprises of one LED projector in each front door and rear door.



*Please read the disclaimer.

Exteriors.

Automatically dimming - Driver's exterior mirror Interior mirror

Enjoy more relaxed driving at night. Depending on the lighting conditions, the inside rear-view mirror and exterior mirror on the driver's side dim automatically. This can help to improve your perceptual safety in the dark and spare your eyes. It is also not necessary to adjust the mirror manually so you can concentrate fully on driving.



*Please read the disclaimer.

Interiors.

New multifunction steering wheel in nappa leather

The new generation 3-spoke design multifunction steering wheel in nappa leather stands for the high-class look & feel of the S-Class. The new ergonomic Touch Control buttons allow intuitive control of most functions. Innovative: Integrated cruise control in the left-hand grip area.

Burmester® surround sound system with 13 speakers

13 high-performance speakers, a 9-channel DSP amplifier with a total output power of 590 W and amplifier/speaker systems configured specifically for the vehicle make for the first-class Burmester sound. If required, this impressive listening experience can be upgraded even further. The surround function generates a virtual all-round sound for maximum spatial impact. Front/rear optimisation allows the sound to be specifically adjusted for the front or rear seats. Thanks to vehicle noise compensation (VNC), the sound quality is maintained despite driving noises so that the best possible music enjoyment is guaranteed at all times – whether on the motorway or in urban traffic.



*Please read the disclaimer.

Interiors.

Wireless charging for mobile phones in the rear

Simply put down and charge – the wireless charging system in the rear requires no plug connectors. The wireless charging system functions with all mobile devices which support or can be upgraded to support the Qi standard. The charging surface is integrated into the quick stowage tray in the front on the centre console and accepts mobile phones with a screen diagonal of up to 15.2 cm (6 inches). A connection is quickly established between the multimedia system and mobile phones via Near Field Communication (NFC) by touching the “NFC” logo. Telephone calls are then conducted automatically via the Bluetooth® hands-free system.

Smartphone Integration - for safe and intuitive smartphone use

With New Telematics Generation 5.5, Smartphone Integration allows integrating iPhones® via Apple CarPlay™ as well as Android smartphones with Android Auto into the vehicle, and operating them by voice control – certain functions can also be used via the vehicle controls. This makes safe use possible while on the move. The connection to the smartphone provides access to the latest software and data such as, e.g. media (streaming media and IP radio), as well contact information, telephony and messaging. To prevent driver distraction while at the wheel, not all smartphone content is duplicated. A data connection via the mobile phone is required to use some of the functions. Data charges may apply depending on the mobile phone contract. For compatible devices and functions, please also see the smartphone’s manufacturer information.



*Please read the disclaimer.

Interiors.

THERMOTRONIC climate control in front

The THERMOTRONIC controls the individual temperature in two zones. You and your front passenger can thus set your preferred climate independently of one another. And you never have to readjust. Because the sensitive sensors even register changes in conditions, such as sunlight. You can also bring a pleasant temperature to the interior if you park the car for a shopping expedition, for example. It's all thanks to the residual engine heat utilisation: Climb back in and immediately feel at home again. The activated charcoal particle filter also works very efficiently, and as well as particulate matter it eliminates harmful substances and unpleasant odours. Your health will thank you for it.

THERMOTRONIC automatic climate control in the rear

Individually adjustable climate comfort for passengers in the rear too: this equipment expands the THERMOTRONIC automatic climate control system to four zones. Temperature and ventilation intensity can be controlled separately for four zones – providing all passengers with their desired feel-good climate.



*Please read the disclaimer.

Interiors.

Sun Protection package

The electrically operated roller sunblinds for the rear window and rear side windows enable the passengers to shield themselves from direct sunshine and prying eyes. The view to the outside is maintained.

The sunblinds consist of a perforated foil which effectively protects against inquisitive looks and direct sunshine. At the same time the special perforations ensure that the view of rear seat passengers to the outside is hardly restricted at all. When not in use, the side roller sunblinds are concealed in a roller mechanism inside each rear door. The roller sunblind for the rear window is discreetly integrated into the parcel shelf.

The roller sunblinds are electrically extended and retracted via keys in the control panels in the rear doors. The roller sunblinds can also be centrally controlled from the driver's door.



Interiors.

Ambience lighting in 64 colours – showcases the high-class interior like a work of art

Futuristic displays in HD resolution, select materials, generous sense of spaciousness – this unique atmosphere in the S-Class spectacularly showcases the ambience lighting also during journeys at night. For example, the indirect LED light complements the elegant lines of the trim and goes one step further: The light showcases the interior like a work of art by composing different colours to form colour schemes. This creates emotively appealing

contrasts and structures the interior in three levels. Eight colour schemes each combine two colours. They are initially orientated towards the display style of the Widescreen Cockpit, either classic, sporty or progressive. The upper part with Widescreen Cockpit and the lower part with footwell are illuminated in the same colour. The centre trim level also offers an exciting contrast. The ambience lighting thus uses the positive influences of light on well-being during the journey.



Interiors.

Rear seat comfort.

The **electrically adjustable rear seats** offer tailor-made travel comfort. The backrests of the two outer luxury seats can be reclined to an angle of up to 43.5 degrees. **Rear Seat Comfort package** features multicontour seats with inflatable air chambers for even more individual adjustment. The ENERGIZING massage function enhances the sense of well-being – if desired also using heat.

HIGHLIGHTS AT A GLANCE

77 mm more kneeroom comes courtesy of the **Chauffeur package** – the front passenger seat can be moved significantly further forward and the EASY ADJUST luxury head restraint on the front passenger side removed for an unobstructed view.



*Please read the disclaimer.

Interiors.

Front Memory package (Available with S 450 Maestro Edition)

The Memory package provides practical ease of operation – especially when your vehicle is used by different people. Besides seat adjustment, the individual position profiles also comprise the alignment of the steering column and exterior mirrors. After a change of driver or front passenger, your position can be restored at the press of a button.

Ergonomic and comfortable: the Memory package also includes 4-way lumbar support. You can use this to adjust the backrest curvature of the front seats individually according to your requirements. This improves the seating comfort and ergonomics. The backrests of both front seats each include two air cushions which are inflated or deflated as required by means of two regulation valves, thereby providing individually adjusted support for the lumbar region. This facilitates individually adjusted support for the lumbar spine. You can also adjust the position of the lumbar support for height – simply by using a 4-way switch integrated in the side panel on the outside of the seat.



Interiors.

Climatised rear seats

Crispness on hot days – warmth on cold days. This is how the advantages of the climate-controlled rear seats can be summed up. The passengers on the outer seats in the second seat row enjoy the same pleasant seating climate as the driver and front passenger. This makes riding in the rear even more comfortable.

COMPONENTS

- Seat climate control for the two outer rear seats:
- 3-stage seat ventilation with fans in seat cushion and seat back
- 3-stage seat heating with heating elements in seat cushion and seat back
- Controls in the door control panels on the driver's and front passenger's side
- Time relay for the seat heating (for automatic reduction of heating output or deactivation after a predefined period)
- Seat ventilation for the outer rear seats

Seat heating for the outer rear seats



Interiors.

Heated seats: Front seats

Pleasant warmth that results in high seating and ride comfort. In cooler weather or as required, seat heating quickly brings the seat cushions and backrests up to a pleasant temperature. Three levels of intensity can be selected. Intelligent and convenient: the intensity of the seat heating is reduced automatically.



*Please read the disclaimer.

Interiors.

COMAND Online

COMAND Online with NTG 5.5 is a navigation system with comprehensive networking and an integral control and display concept. With LINGUATRONIC voice control you can communicate your desired navigation destinations to your vehicle, call up contacts from the address book, have messages read out or control vehicle functions – a simple command can be used to switch the seat heating on or off, for example. You will find the latest information on traffic conditions, lane recommendations and much more on a high-resolution 12.3-inch display. Get to your destination faster and in more relaxed style with COMAND Online, the navigation system which is perfectly integrated into the cockpit featuring the Mercedes look and feel.

COMAND remote control

Take control of COMAND Online for yourself. With the remote control you can conveniently control the functions of the control and display system from the rear.



*Please read the disclaimer.

Interiors.

Touchpad with Controller

The control elements for the multimedia system are located in the centre console: the touchpad, Controller and direct-access keys are ergonomically arranged. The touch-sensitive touchpad is of high-quality design and is integrated into the handrest for the Controller. It responds to one and two-finger gestures: swiping movements are used to navigate in the menu, while spreading movements enlarge the content and inputs are confirmed by the touch of a finger. The touchpad even recognises your handwriting – i.e. letters, special characters and figures. This character recognition function enables you to enter addresses or telephone numbers very quickly.



Interiors.

Double Cupholder

You can always have a refreshing or warming drink within reach. This is made possible by the double cup holder in the front section of the centre console. You can safely deposit two bottles or mugs in it. And if you remove the double cup holder, you add a large stowage tray to the interior.



*Please read the disclaimer.

Interiors.

Velour floor mats

The velour floor mats additionally enhance your interior. They are finished in the respective appointments colour and edged. As such they blend into the interior design perfectly. In addition the mats protect the footwell against dirt – they can be removed easily to be vacuumed or cleaned.



*Please read the disclaimer.

Interiors.

Power Closing

This is how quality sounds and feels: the power closing feature closes the doors and boot lid smoothly and almost silently. For this you only need to close them as far as they start to engage – and your vehicle will take over the rest for you.



*Please read the disclaimer.

Rear Seat Entertainment System.

Films on Blu-ray or DVD, TV, internet, video games, music – the Individual Entertainment System gives passengers in the rear their very own personal entertainment programme. In combination with high-quality wireless headsets, two 25.9 cm (10.2-inch) displays on the front seat backrests ensure brilliant picture and sound quality. The system is conveniently

operated using a remote control. It includes a Blu-ray player, is networked with COMAND Online and also has ports for connecting external devices. The passengers are each able to access the entertainment source of their choice. Via connections in the rear armrest, content from MP3 players, games consoles, USB sticks, iPod® or iPad® is also available.



*Please read the disclaimer.

Panoramic sliding sunroof with MAGIC SKY CONTROL MAGIC SKY CONTROL (Available with S 450 Maestro Edition)

Technically sophisticated and very flexible to use. Enjoy something of an open-air ambience when the front segment is in the classic sliding sunroof position. When it remains closed, it combines with the rear section above the rear to create a large panoramic glass area. You can switch both segments to light or dark independently of each other with MAGIC SKY CONTROL.



*Please read the disclaimer.

Panoramic sliding sunroof – light and air well balanced.

With its large glazed areas, this roof system ensures a particularly bright and welcoming ambience in the interior. It consists of a fixed panoramic glass rear section and an electrically operated glass front section sliding on outside rails with a meshed air deflector. In addition, two electric roller sunblinds provide shade for the occupants in strong sunlight. The panoramic sliding sunroof has numerous useful functions for a high level of travelling comfort. In the raised position, the glass roof automatically adjusts in three stages to suit the current vehicle speed.

The glass roof is lowered at high speeds. The noise level and air circulation in the interior are reduced. Conversely, it raises itself again at low speeds. The panoramic sliding sunroof also responds automatically to rain: If it is open, it automatically moves to the raised position to prevent rain from entering the interior. When the vehicle is parked, the panoramic sliding sunroof can also be opened and closed from outside. The “summer opening” and “convenience closing” functions of the electronic ignition key can be activated by holding down the respective buttons. To prevent e.g. a hand from being trapped, the panoramic sliding sunroof has an obstruction sensor.



Accessories.

Vehicle key in black gloss finish

On the Cabriolet you can also operate the fully-automatic soft top via the key's unlock button.



2 Wireless Head Sets

A totally personalised multimedia experience – listen to your favourite song or enjoy your favourite film, without disturbing other passengers. The sets of wireless headphones featuring a high-quality finish boast high wear comfort, even when used for longer periods.



*Please read the disclaimer.

Mercedes me connect (Available with S 450 Maestro Edition)

The communications module (LTE) offers you a definite advantage in terms of convenience and safety. It provides your vehicle with a connection to the internet – allowing you to make use of helpful services from Mercedes me connect. Two mobile phone antennas and an LTE-compatible SIM card ensure a fast connection.

Let your personal digital assistant take the experience to an all new level in your everyday life.

- ✓ Stay informed. About your Mercedes-Benz and everything associated with it. Tyre pressure: okay! Fuel tank: nearly full!
- ✓ Off to new places: You can directly send any type of destinations to your vehicle from your smartphone.
- ✓ Relax on the road. Calmly complete your first conference call during your journey as the navigation system plots the ideal route to your next meeting.

All-in-one service package: Get reminders and never miss a service appointment, conveniently book your service appointment online.



Vehicle Monitoring (Available with S 450 Maestro Edition)

Parked Vehicle Locator: Unfamiliar city, winding streets – where was it you parked? Your smartphone knows the answer. It can locate your parked vehicle within a radius of 1.5 kilometres and show you on a map how to make your way back to the vehicle.

Vehicle Tracker: Perhaps a family member is driving your car and you wish to know its current whereabouts. The app knows the answer. For this purpose, your vehicle's geo-coordinates are sent by GPS. The driver receives a message that they are being geolocated. The driver can deactivate the Vehicle Tracker at any time with a free call to the Customer Assistance Center (model-specifically, also via the multimedia system).

Speed alert: Receive an alert if your vehicle exceeds a certain speed. The notification is sent directly to your smartphone by an app. This is where you can set the desired threshold value (from 0 to 255 km/h), and obtain a list showing when and where the speed was exceeded. This allows you to stay informed when someone else is using your vehicle.



Vehicle Monitoring (Available with S 450 Maestro Edition)

Vehicle Set-Up: Full control, any time, anywhere: the Vehicle Set-Up app on your smartphone also allows you to change settings and retrieve information remotely.

Remote Retrieval of Vehicle Status: You have easy access at all times to the most important information about your vehicle – available from the Mercedes me App or the Mercedes me Portal. These include mileage, tyre pressure, washer fluid level, fuel tank level and also when the next service is due.

Remote Door Locking and Unlocking: We've all done it: no sooner have you left the vehicle than you suddenly can't remember whether or not you locked the doors. With the Mercedes me App or from the Mercedes me Portal, you always have certainty – and can lock the doors later if needs be. And if you ever lock yourself out, if your passengers are already waiting next to the car or if a friend needs to go back and fetch something from inside the vehicle, you can unlock the doors remotely. In this case, you receive a corresponding acknowledgement on your smartphone.

Send2Car function: Smartphone and car, more connected than ever before: found a place of interest or the best restaurant in town? You can easily send the address to your vehicle via an app. You just need to confirm the import and the data will be integrated into your navigation system.



Navigation Connectivity package

In combination with the standard-fit communication module (LTE) and the hard-disc navigation makes sure that you always reach your destination as quickly as possible by the best route. Enhanced Navigation Services can even provide you with predictive information: You are provided with optimised travel destinations and your vehicle can answer questions about your journey, such as current filling petrol station prices along the route.

Mercedes-Benz emergency call system

The Mercedes-Benz emergency call system can save you vital minutes in an emergency. If an accident is detected, a communications module with its own SIM card automatically triggers an emergency call which can shorten the time until the rescue services arrive. In the case of a connection with the Mercedes-Benz emergency call centre, a member of staff will support you over the voice connection until the rescue services arrive. This means that you are not left on your own in a stressful situation. Alternatively, an emergency call can be triggered manually to organise assistance.



Upholstery and trim.

Upholstery

201 Black

205 Silk beige/Espresso brown

214 Nut Brown/Black (Available with S 450 Maestro Edition)



Trim

High-gloss brown eucalyptus wood trim (Available with S 450 Maestro Edition)

Open pore ash wood trim (Available with S 350 d)



Paintwork.

Metallic paints

197 Obsidian black

775 Iridium silver



Metallic paints

890 Cavansite blue

897 Ruby black



Metallic paints

998 Anthracite blue

799 Designo Diamond White Bright



Alloy.

Alloy

45.7 cm (18-inch) 5-twin-spoke light-alloy wheels
in high-shine finish



Technical data.

	S 450 Maestro Edition	S 350d
No./arrangement of cylinders	V6	L6
Transmission (gearshift type)	Automatic	Automatic
Displacement (cc)	2996	2925
Rated output (kW (hp) at rpm)	270 [367]/5500-6100	210 [286]/3400-4600
Rated torque (Nm at rpm)	500/1600 - 4000	600/1200 - 3200
Acceleration 0-100 km/h	5.1 secs	6.0 secs
Top speed	250 km/h	250 km/h
Fuel	Premium unleaded	Diesel

Dimensions.

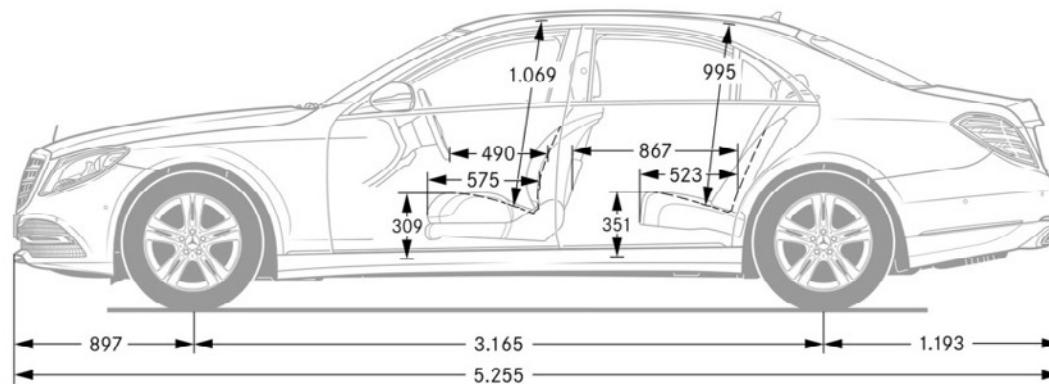
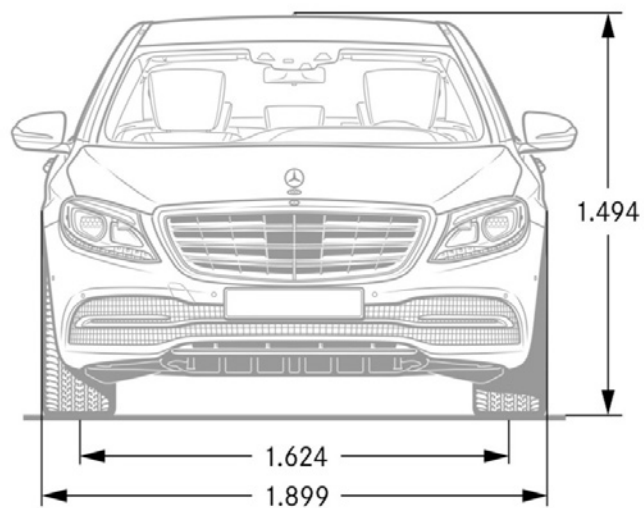

All dimensions in millimetres. The dimensions shown are mean values and apply to standard-specification, unladen vehicles. The dimensions shown correspond to vehicles with a petrol engine.

*Please read the disclaimer.

My Mercedes. My Service.

You enjoy life. We'll take care of your Mercedes.

The best or nothing! This statement conveys how Mercedes-Benz aspires to develop and build highly desirable, top-class vehicles. The same passion, pledge and commitment apply to the Mercedes-Benz Service too. The bouquet of world-class After-Sales products will not only attend to every need of your Star but will also redefine the concept of ownership experience with a focus on providing end-to-end customer delight. After all, your Star deserves nothing less than the best.

STAR EASE

Delivering the best-in-class value

Servicing your Star does not get any better than this. With the STAR Ease Maintenance Packages, pay a defined cost of maintenance based on the model, contract period and mileage and say goodbye to spending on service every time. Plus, enjoy exclusive features like priority handling, shorter waiting time and quicker processes.

Advance Assurance Program

Extending your warranty coverage

With Advance Assurance Program, experience complete peace of mind. While this Extended Warranty Program kicks in the moment your standard 3 years warranty comes to an end, it can be extended further up to 6 years at a nominal price. Also, it comes with a bouquet of privileges for a worry-free time with your Star.



*Please read the disclaimer.

My Mercedes. My Service.

MOBILO

Providing you 24x7 mobility support

Your vehicle comes with Mobilo which provides round-the-clock on-road assistance service. Mobilo comes as a standard for 3 years and can be extended further up to 8 years at a nominal cost. This service offers privileges like vehicle towing facility, replacement vehicle, hotel accommodation, just to name a few.

Digital Service Drive

Ensuring convenience and transparency of service.

Servicing your Star is the last thing you will ever have to worry about. We provide transparent, convenient and hassle-free service. Our customer-friendly service features work around your busy schedule so that you have one less thing to focus upon.

Now booking your appointment is quick and easy.

To book your online service appointment, visit <http://mb4.me/SelectDealer>



*Please read the disclaimer.

My Mercedes. My Service.

Premier Express*

Because we value your time as much as you do.

Life gets busy and so we have designed Premier Express, our vehicle care service to help you get in and out quickly. While the visit will be brief, the service offered by our technicians will be comprehensive and complete. All to ensure your Mercedes-Benz is running for miles to come.

*Available at select locations only



Mercedes-Benz Genuine Parts

Now with 2 years* of warranty

Mercedes-Benz Genuine Parts are crafted to the state-of-the-art standards of Mercedes-Benz, protecting your vehicle's performance while maintaining the style, comfort and safety, for the years to come. Also, they come with a warranty of up to 2 years, ensuring you a peaceful ownership experience with your Star.

* Terms & Conditions Apply



*Please read the disclaimer.

My Mercedes. My Service.

Mercedes-Benz Approved Tyres and Rims Ensuring every ride is a safe and joyful one

Maximise the safety and comfort of your Star with Mercedes-Benz approved tyres and rims. While the Mercedes-Benz approved tyres are designed to optimally match your car's performance, the Mercedes-Benz approved rims are designed to lend an exceptional style to the exterior of your Star and are also engineered for optimal performance.



Mercedes-Benz Genuine Chemical Products Because your Star deserves nothing but the original

Mercedes-Benz Genuine Chemical Products are specially tested for compatibility with the materials in our cars and meet the high quality standards. Also, our products have been approved under Daimler AG's strict, self-imposed environmental norms. Now with Mercedes-Benz Genuine Chemical Products, experience a whole new world of superior products that support throughout the car's life cycle.



*Please read the disclaimer.

Mercedes-Benz India Private Limited: E-3, MIDC Chakan - Phase III, Chakan Industrial Area, Kuruli & Nighoje, Tal: Khed, Pune - 410 501 (India)

Toll free No.: 000800050 1888. e-mail: cs.ind@cac.mercedes-benz.com, **website: www.mercedes-benz.co.in**

Please note: This brochure is intended for general information, description and illustration of the Product including optional functions and equipment and may not be specific to a Product since specification of a product may change from time to time. Optional features, functions and equipment etc. may not be present in the Standard or Variant Product or Special Edition Product. Further, Standard specifications of a product may also vary from time to time. Colours may differ from those shown in pictures in the brochure, owing to printing. Mercedes-Benz India reserves the right to make changes, at any point of time, without prior notice, in design, colours, materials, components, equipment, specifications, features, functions, make and models etc. The information given in this brochure shall be regarded as accurate at the time of going to print and may vary thereafter due to any developments or any other reason. Interested parties should confirm with the Authorised Dealer about the correct specification of the product they desire to purchase. For the latest authentic information and updates, kindly contact your nearest Authorised Dealer.

All title, ownership rights and intellectual property rights in and relating to this brochure / magazine or publication material or any copies thereof including but not limited to copyright, logos, names, trademarks, service marks, design, text, images, links, concepts and themes are owned by Daimler AG and/or its subsidiaries collectively or used under authorised license by the Daimler AG. Any reproduction, transmission, publication, performance, broadcast, alteration, license, creation of derivative works or other use in whole or in part in any manner without the prior written consent of the Daimler AG is strictly prohibited.

Mercedes-Benz cars: The S-Class meets Bharat Stage VI emission norms.

CIN - U34102PN1994PTC083160